

Monaco™

Monaco by Architectural Railings & Grilles
(704) 365-5152

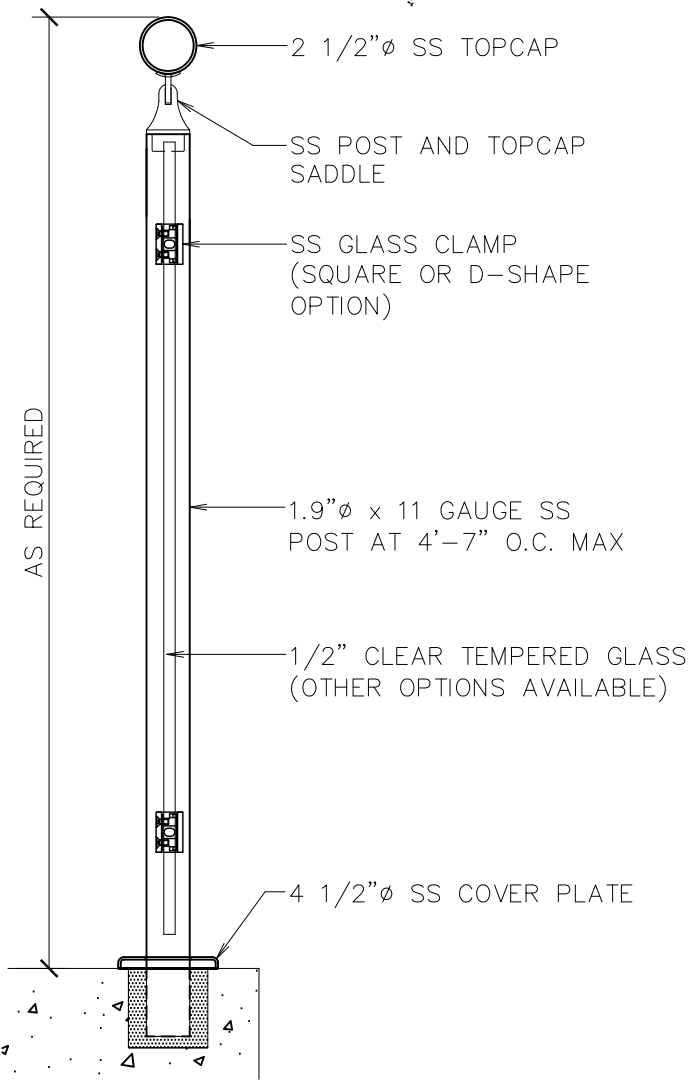

RAIL DESIGN: Monaco



Architectural
Railings & Grilles
Fort Mill, SC
(704)-365-5152

Please visit our
website for
available options
and materials.
www.stainless-railing.com

Monaco™

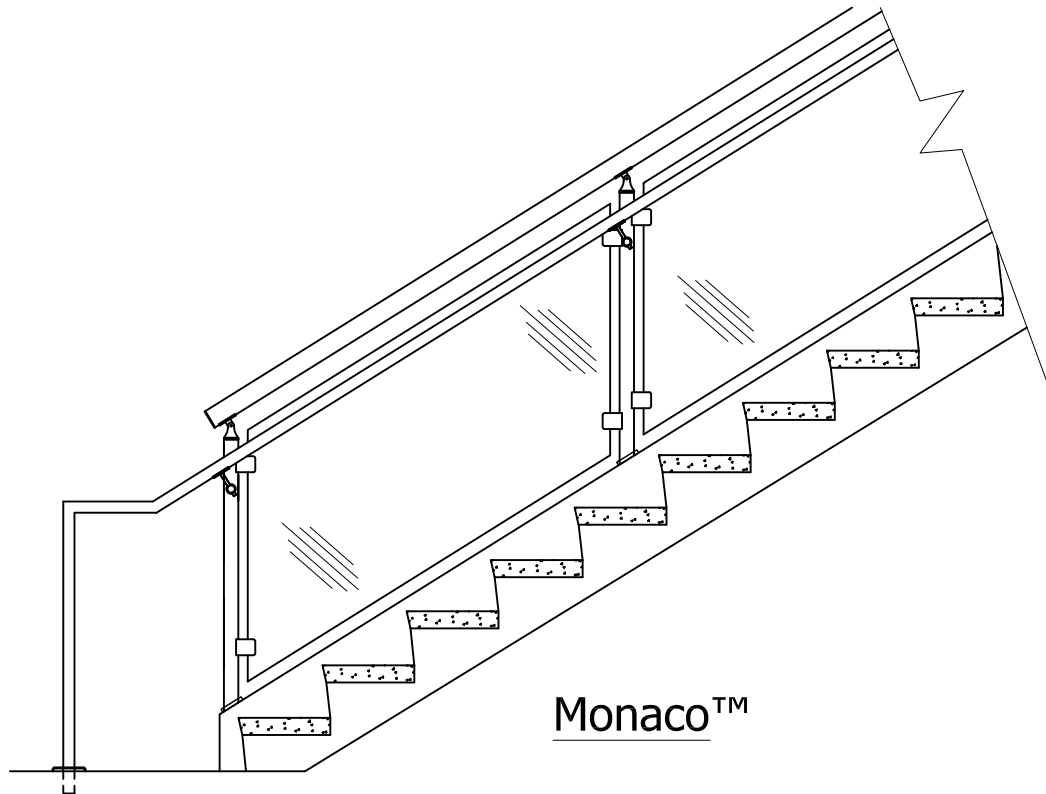

Monaco by Architectural Railings & Grilles
 (704) 365-5152

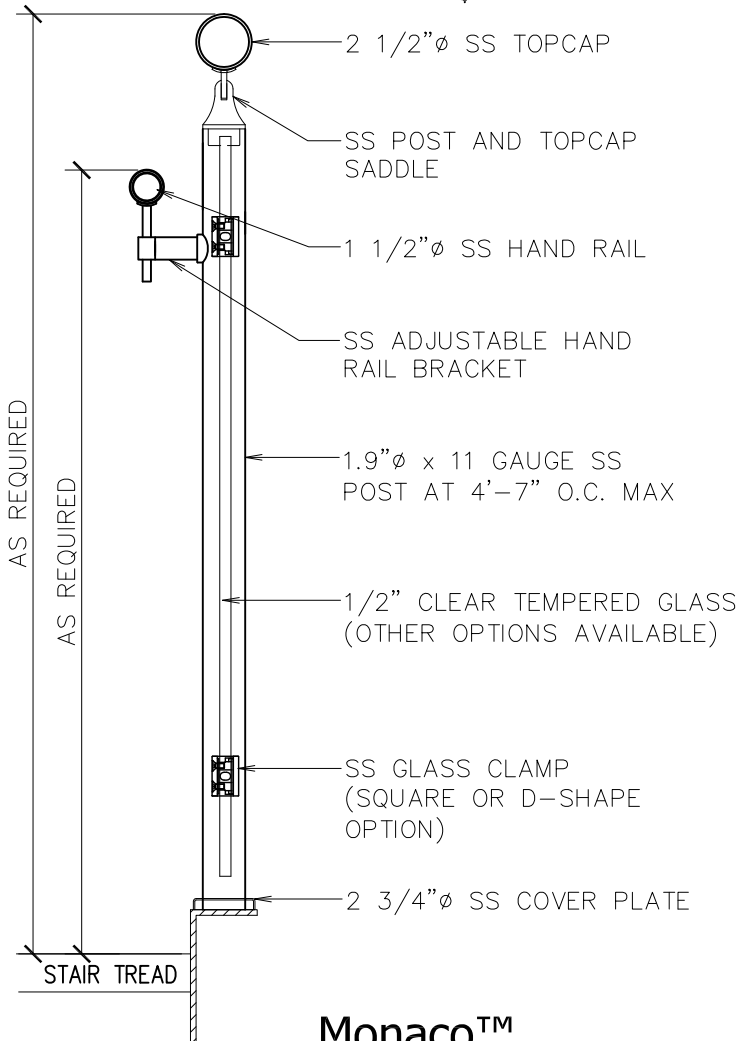

RAIL DESIGN: Monaco



Architectural
 Railings & Grilles
 Fort Mill, SC
 (704)-365-5152

Please visit our
 website for
 available options
 and materials.
www.stainless-railing.com

Monaco™

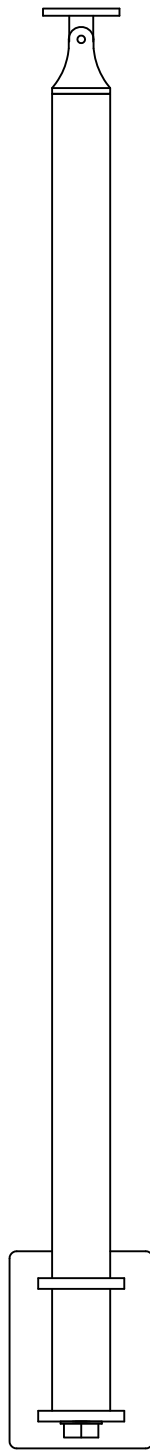
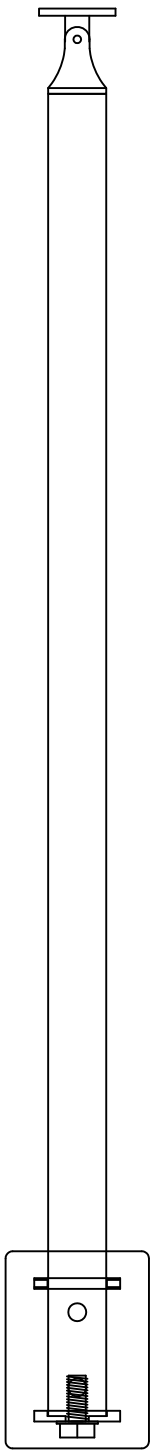

SIDE MOUNT
BRACKET ELEVATION

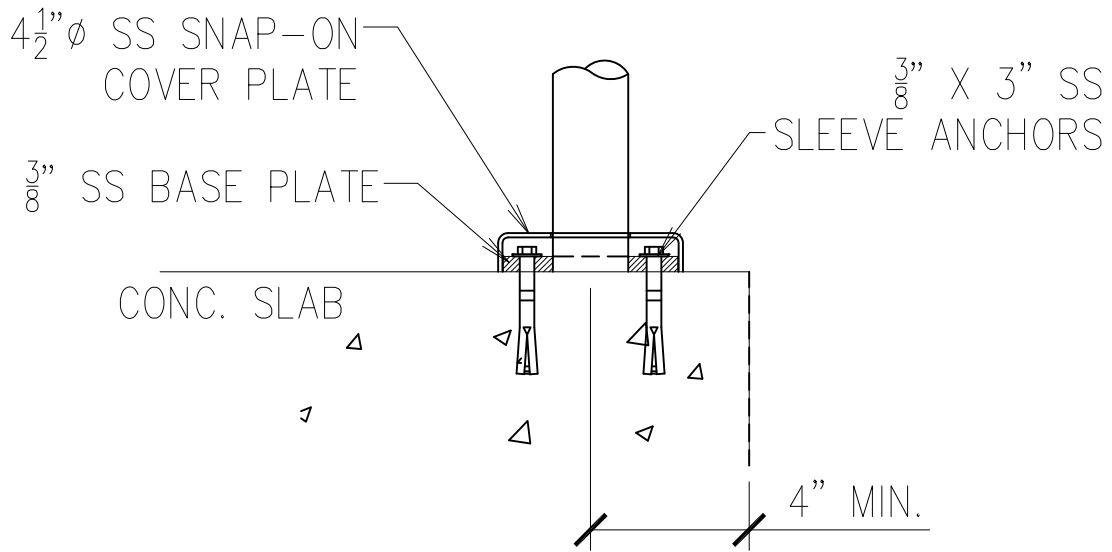

BASE PLATE MOUNTING

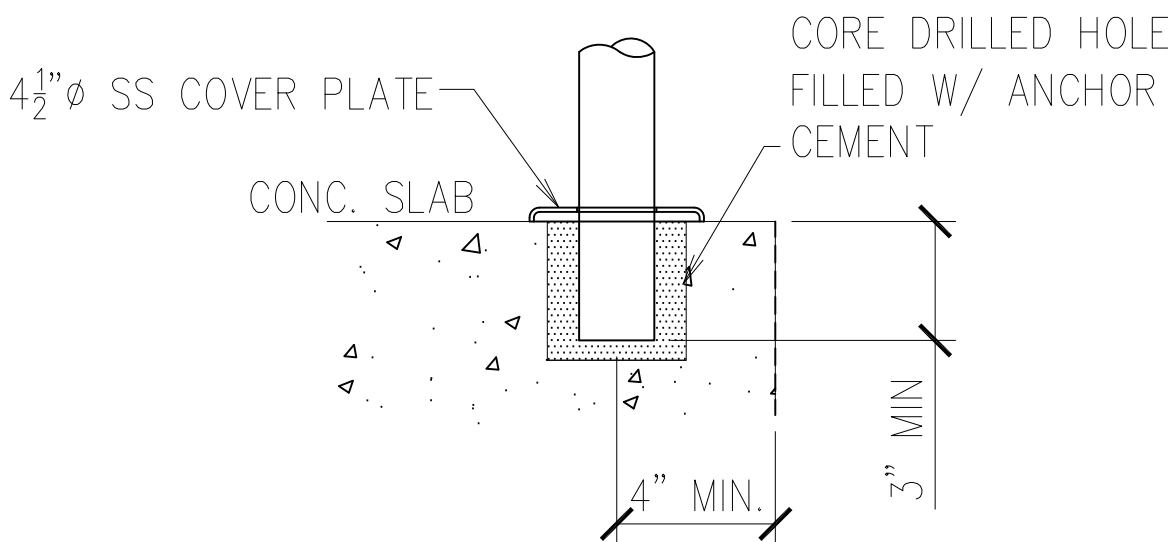

CORE DRILL MOUNTING

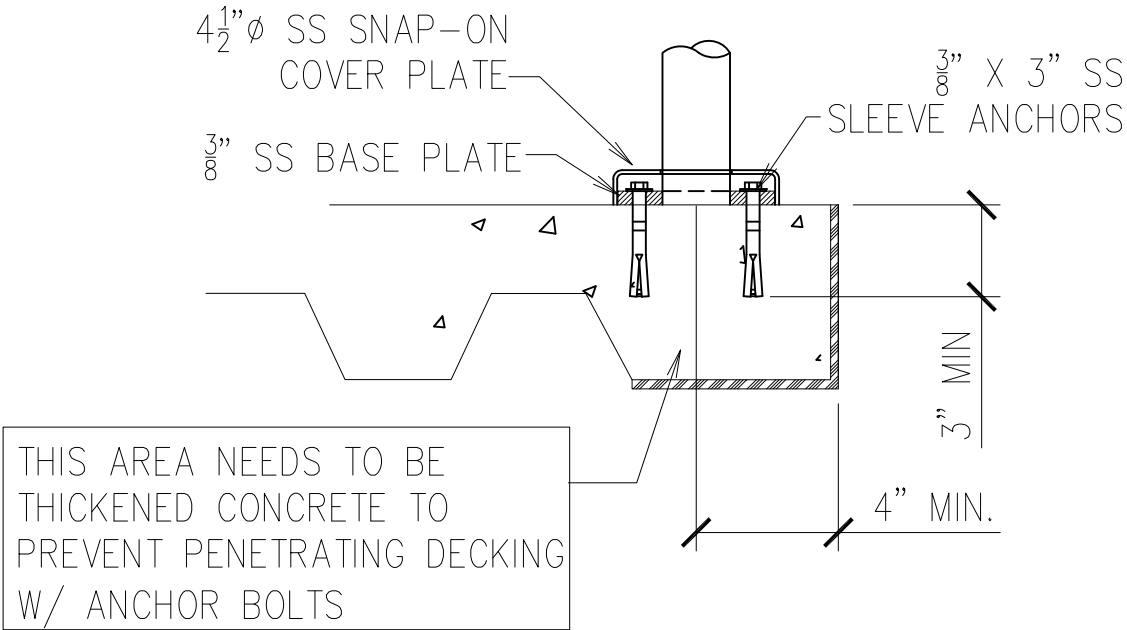

CORE DRILL MOUNTING
OVER CORRUGATED DECKING

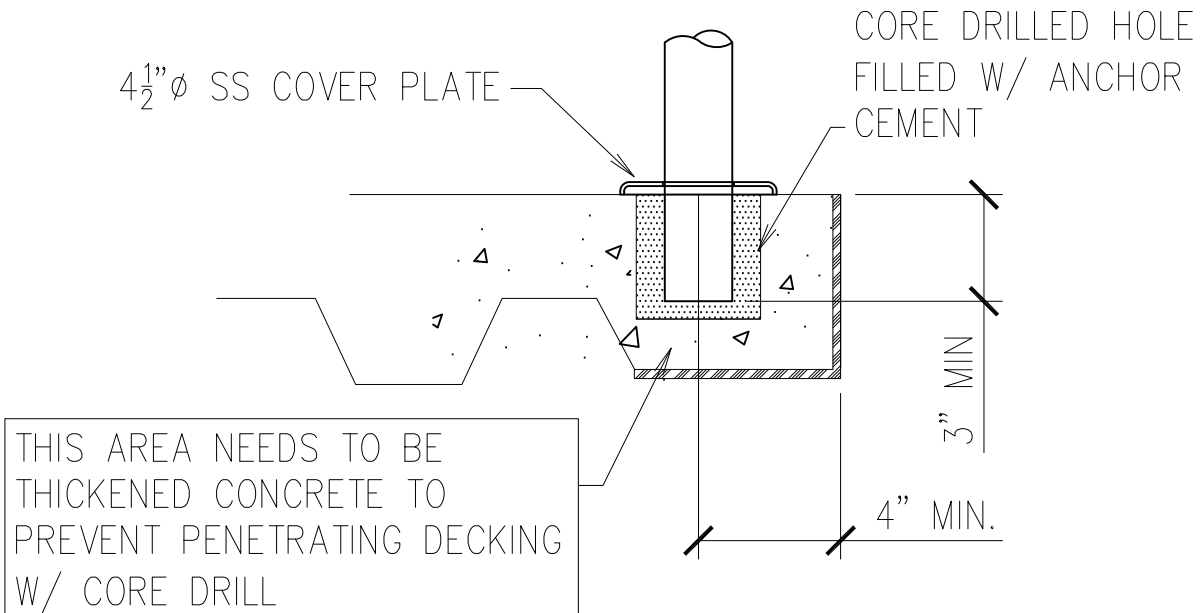

CORE DRILL MOUNTING
OVER CORRUGATED DECKING

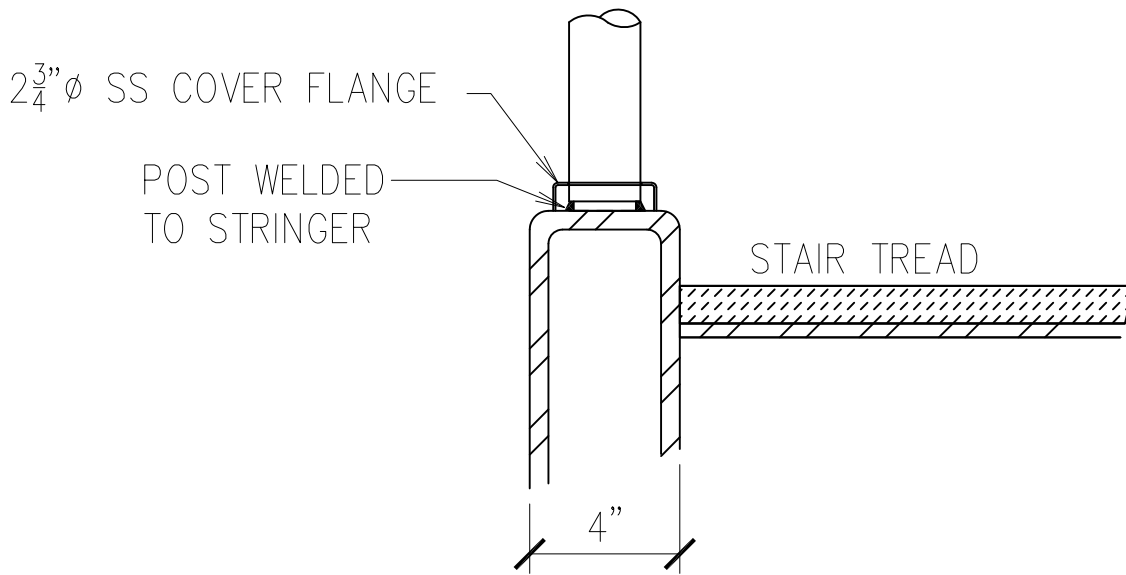

WELDED STAIR MOUNTING
(4" TUBE STRINGER)

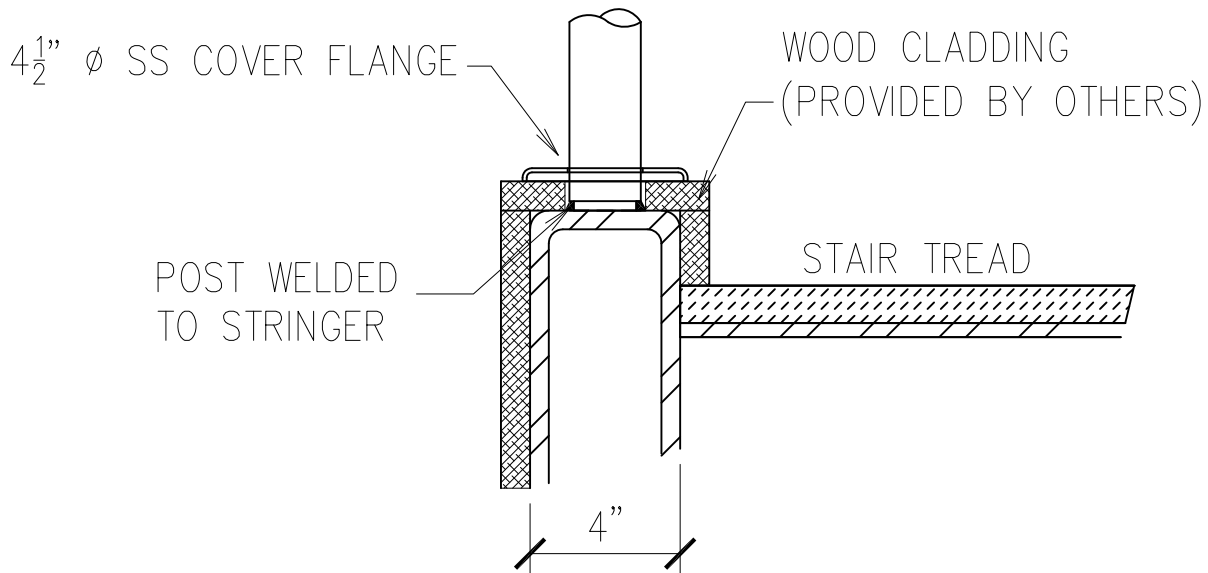

WELDED STAIR MOUNTING
W/ WOOD CLADDING

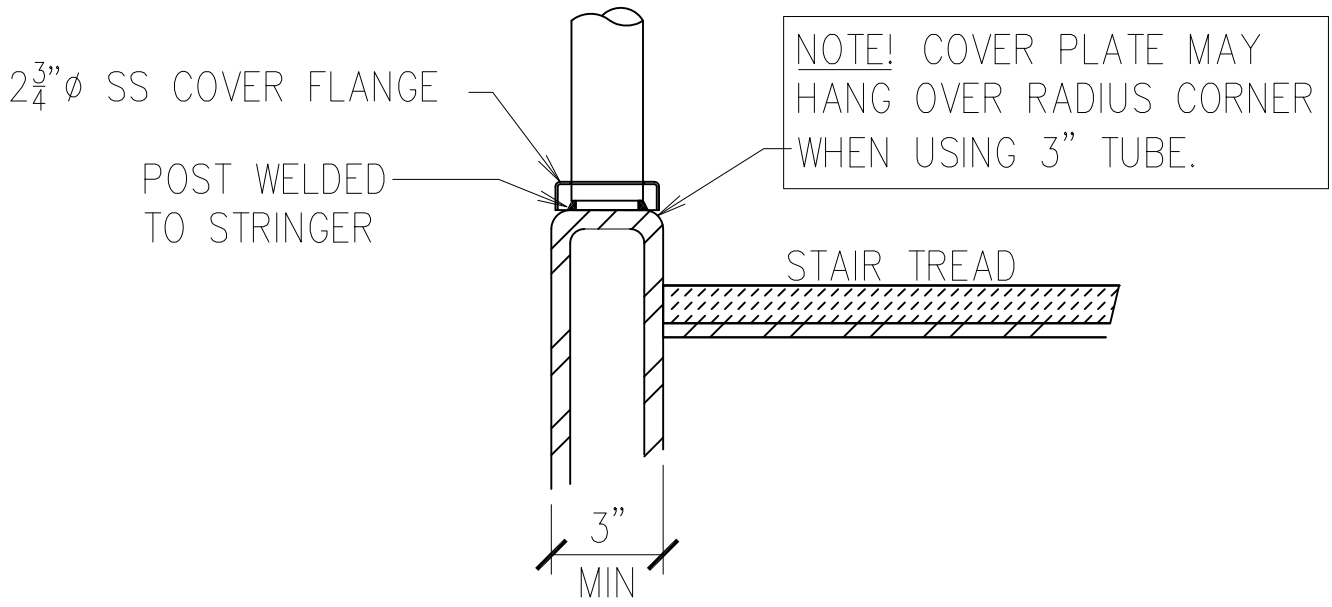

WELDED STAIR MOUNTING
(3" TUBE STRINGER)

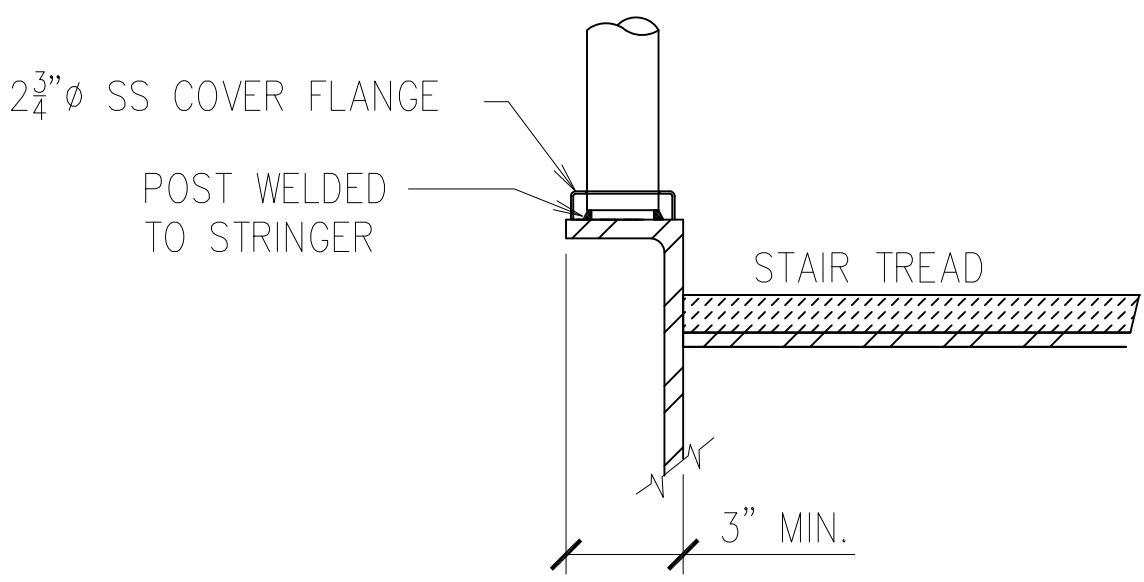

WELDED STAIR MOUNTING
(CHANNEL STRINGER)

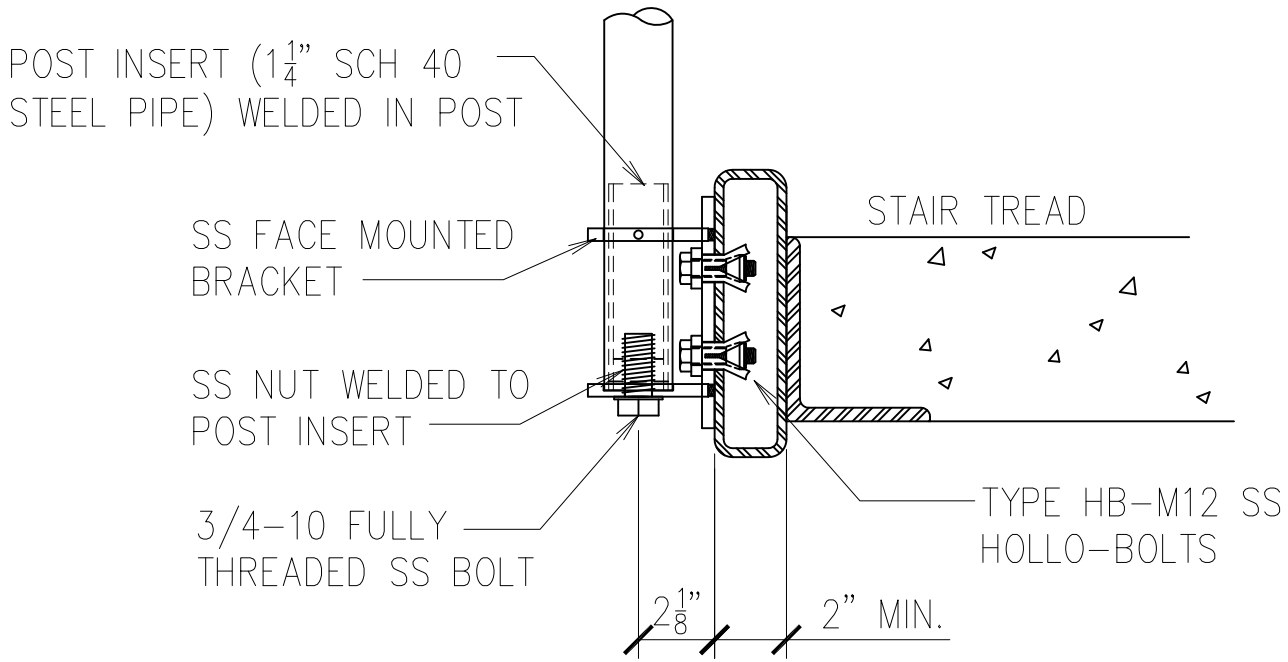

SIDE MOUNTED STAIR MOUNTING
(TUBE STRINGER)

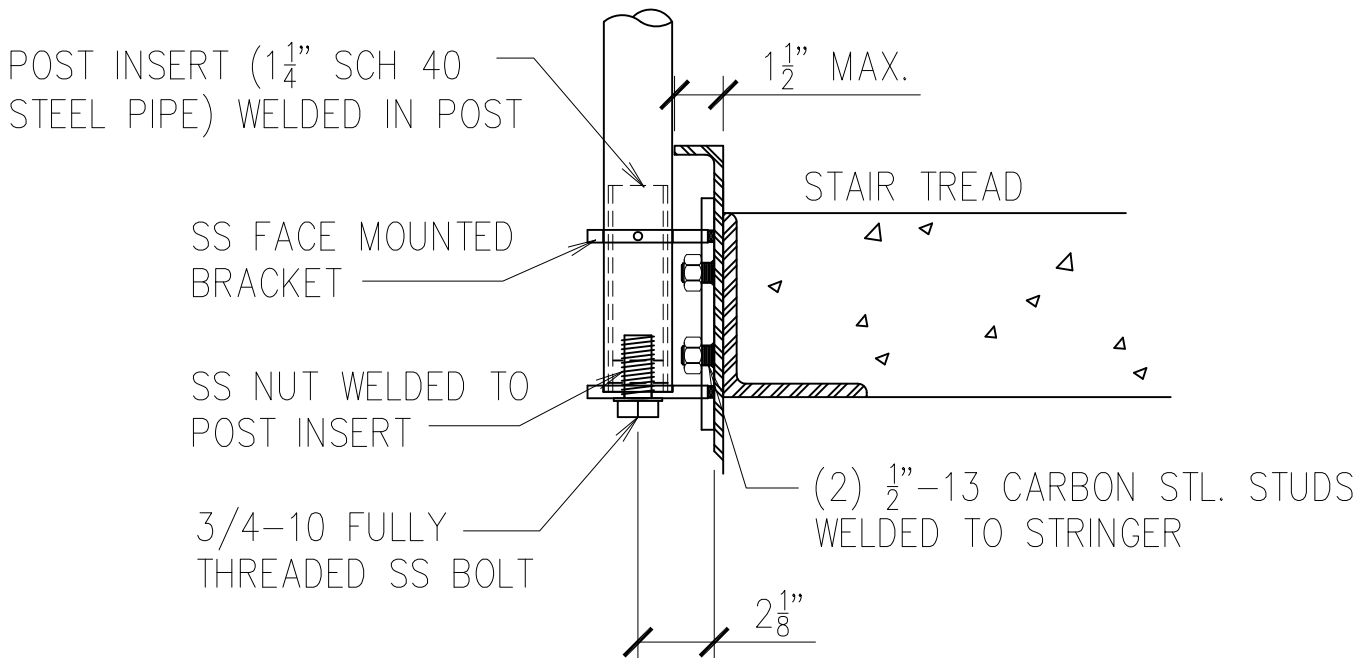

SIDE MOUNTED STAIR MOUNTING
(CHANNEL STRINGER)

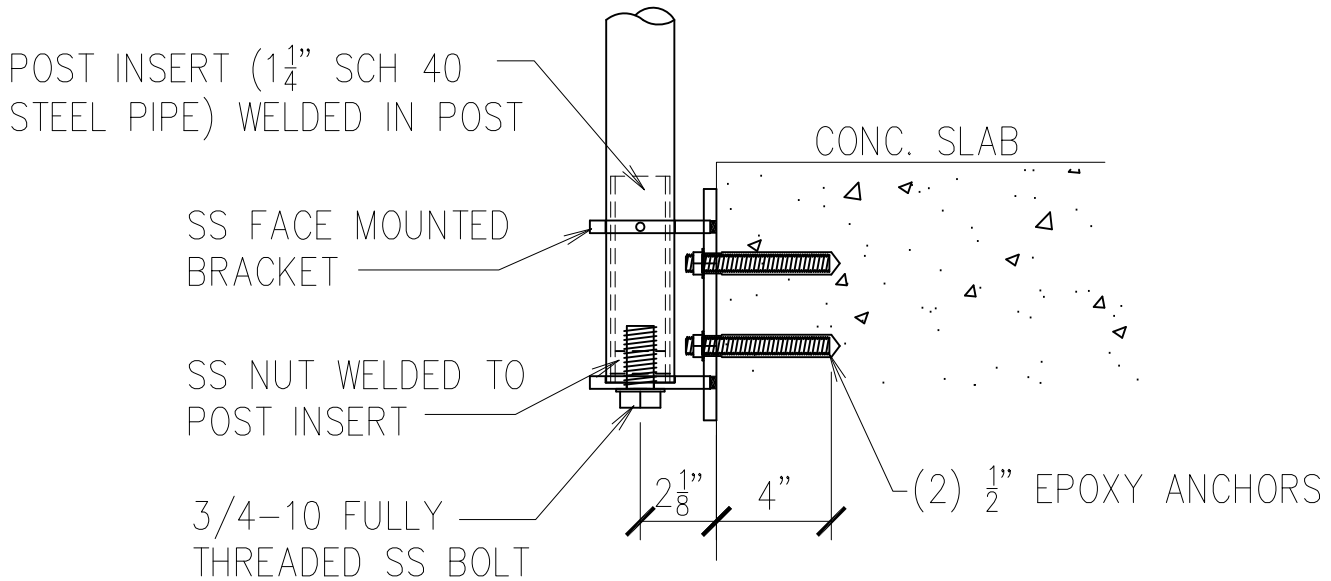

SIDE MOUNTING TO
CONCRETE SLAB

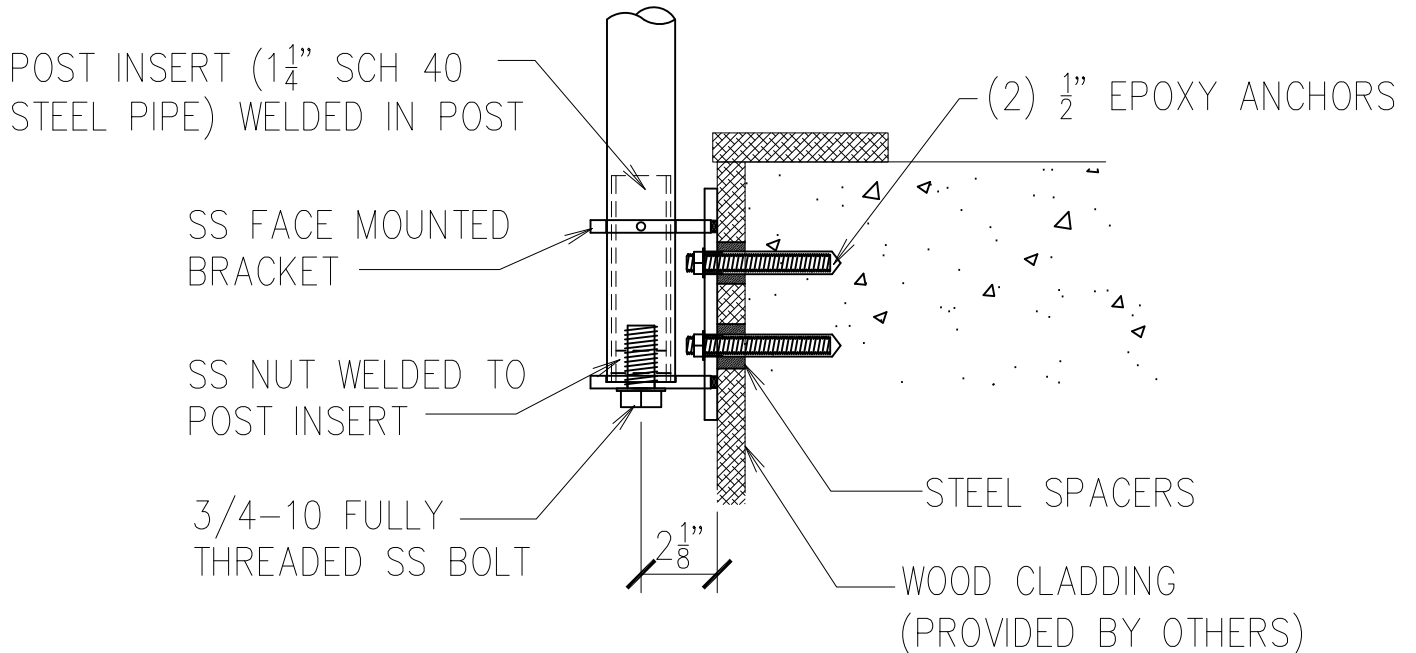

SIDE MOUNTING TO
CONCRETE SLAB OVER
WOOD FACIA OR SHEETROCK

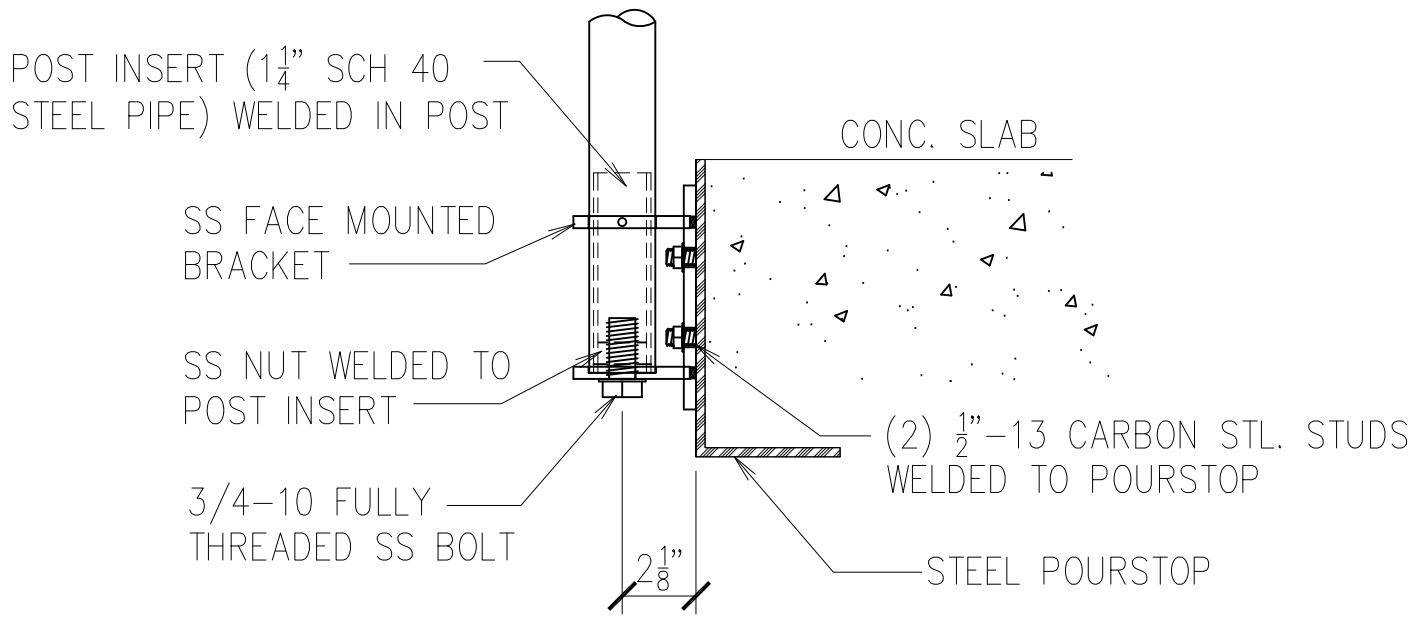

SIDE MOUNT ATTACHED TO POURSTOP

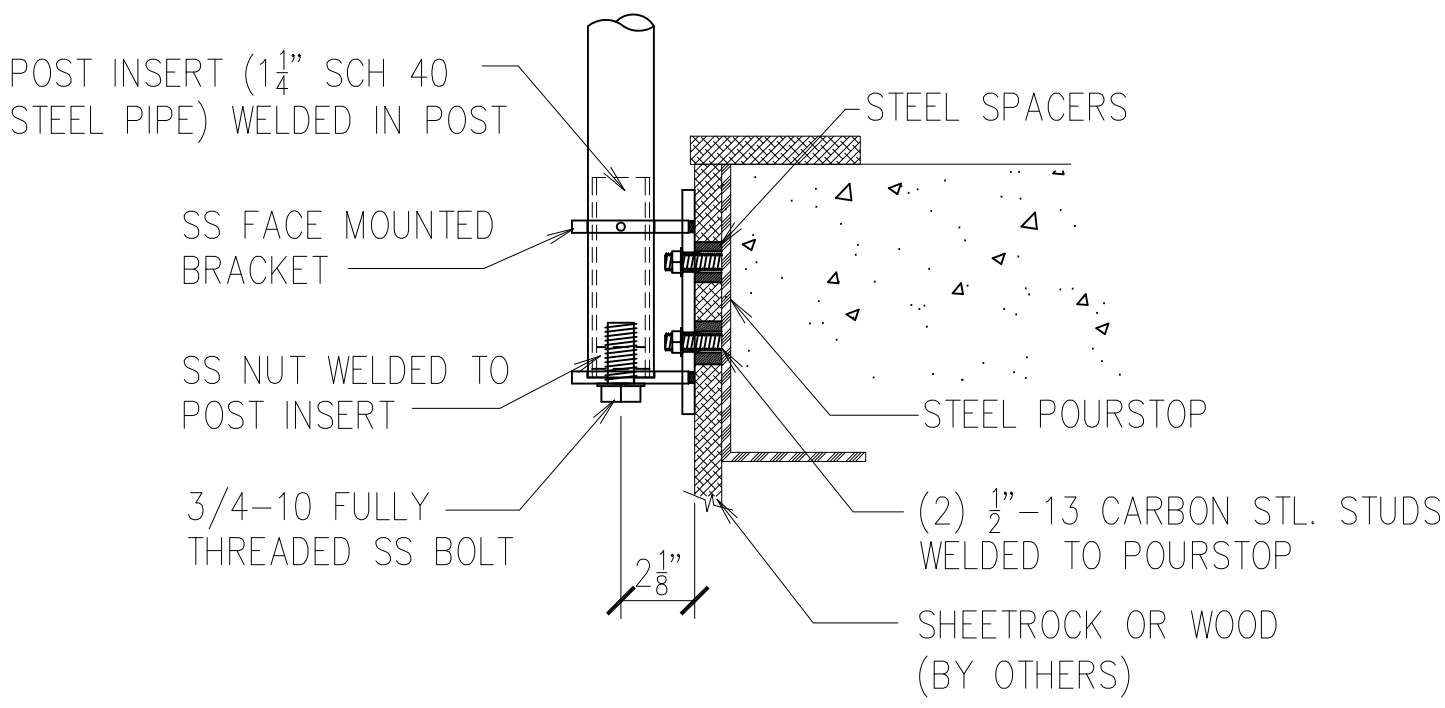

SIDE MOUNT ATTACHED TO POURSTOP OVER WOOD FASCIA OR SHEETROCK